



Futaba

1M23N40301

# 4D ACRO MOTOR GIMBAL ASSY

この製品は小型 EP アクロ機の推力スラスト方向を可変させるユニットです。ピッチ軸・ヨー軸の2サーボによりプロペラ推力スラストを可変します。エレベーター・ラダーとの組み合わせで従来の常識を覆すトリッキーなフライトが可能となります。

- 推奨機体：SkyLeaf-ST (EPP アクロ機スパン 800 mm クラス胴体板厚 10 mm)
- 推奨モーター：PSM-2305 1620kV
- 推奨サーボ：PS-10×2 (ピッチ軸・ヨー軸)

## 付属部品

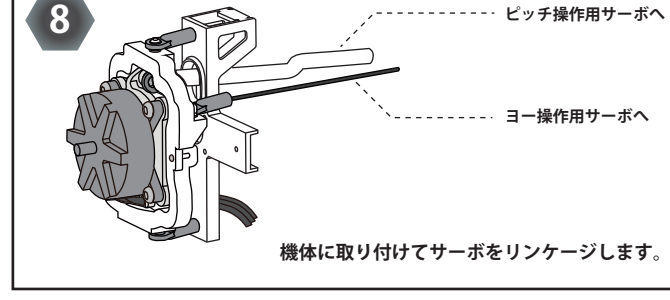
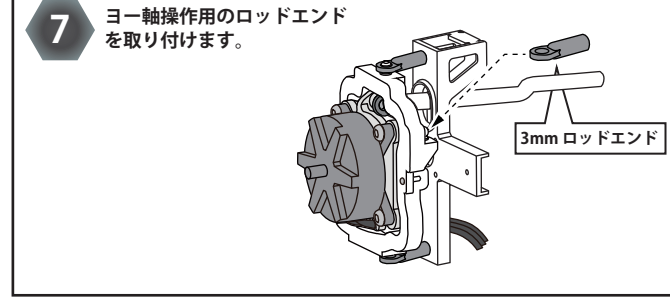
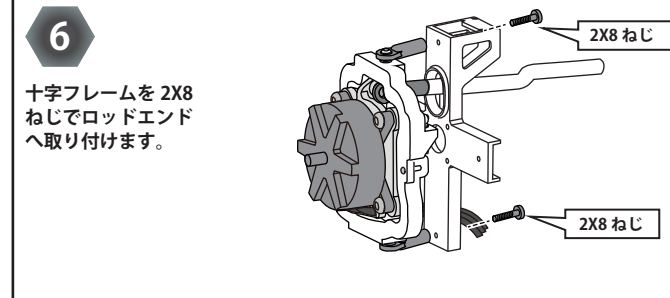
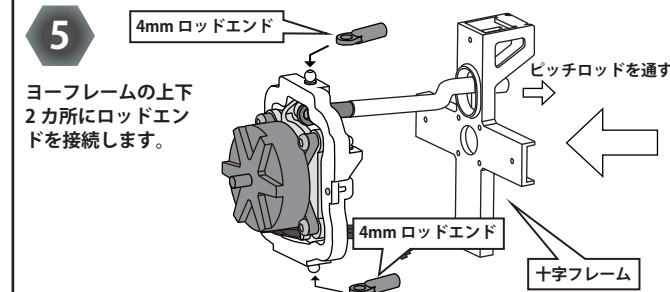
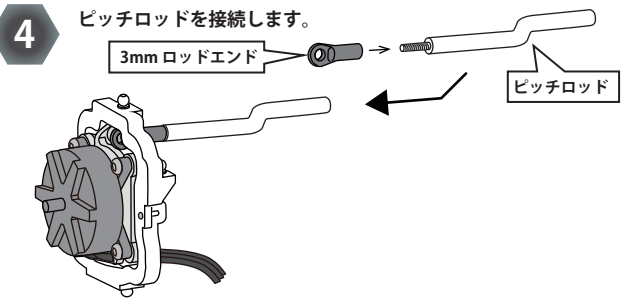
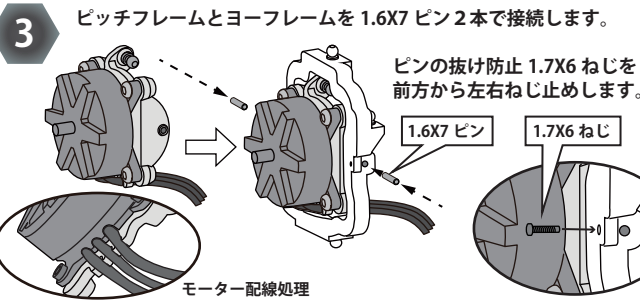
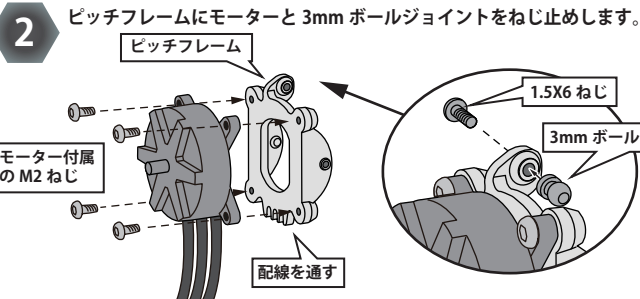
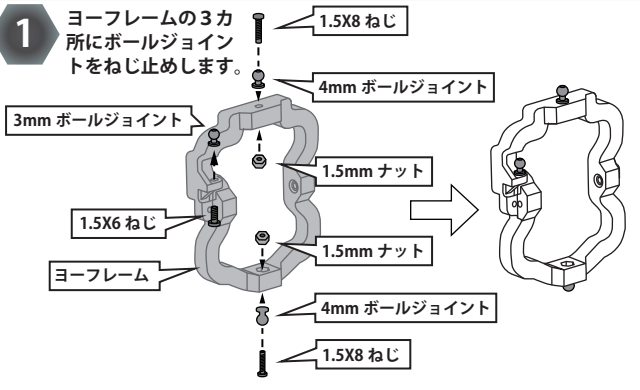
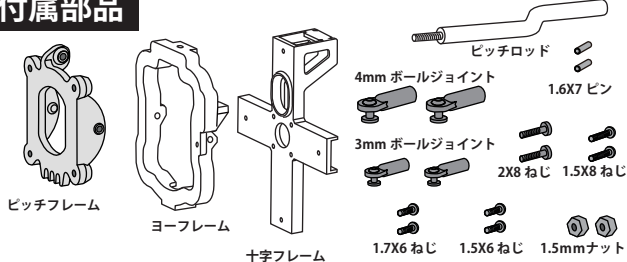

**⚠ 危険**  
**4D アクロフライトについて**  
推力スラストを可変させる 4D アクロフライトは、はげしい動きで、予期せぬ動作がおきる危険性があります。4D アクロフライトは、飛行技術がある方が、十分にテストフライトを行なってから人や建物・自動車などに被害がおよばない安全な場所で、操縦者自身もヘルメット、防護メガネを付けるなど十分に安全に考慮して、自己責任にてお楽しみください。



Futaba

1M23N40301

# 4D ACRO MOTOR GIMBAL ASSY

This unit changes the thrust direction of the small EP acro plane. Propeller thrust is variable with two servos of pitch axis and yaw axis. In combination with the elevator and rudder, tricky flight that overturns conventional wisdom is possible.

- Recommended aircraft: Futaba USA SkyLeaf-ST (EPP ACRO wingspan 800mm)
- Recommended motor: Futaba USA PSM-2305 1620kV
- Recommended servo: Futaba USA PS-10 x 2 (pitch axis, yaw axis)

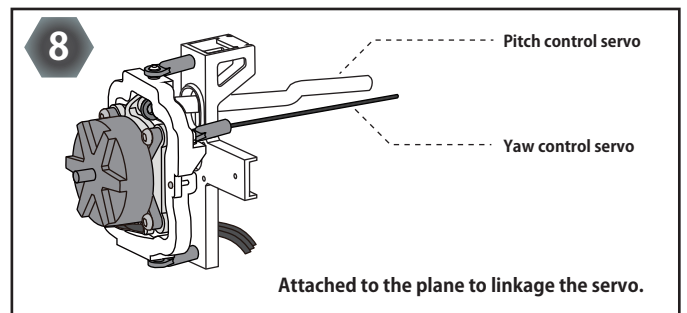
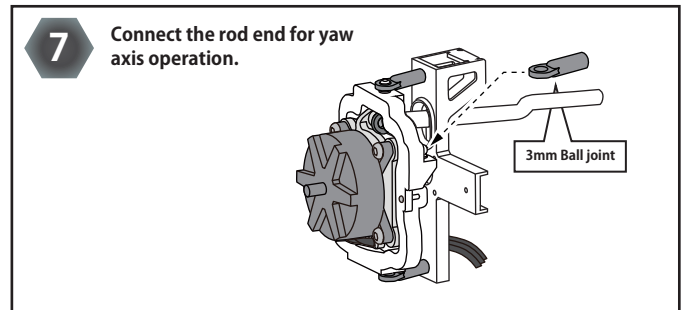
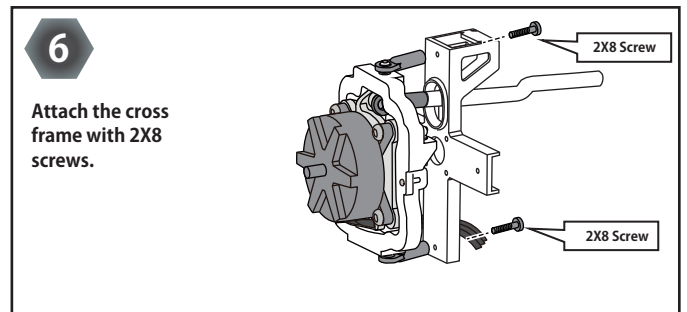
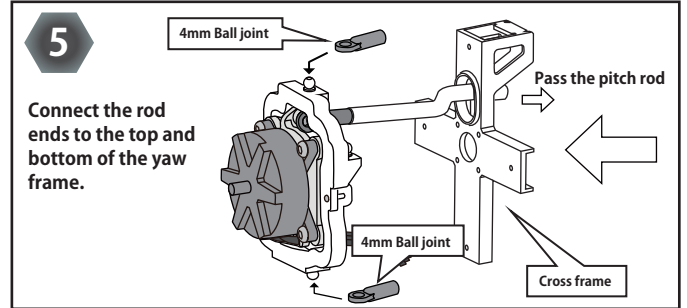
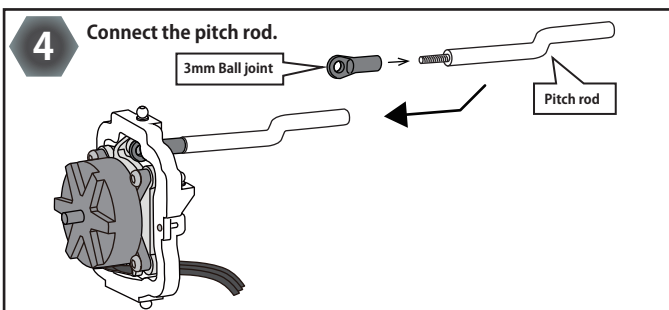
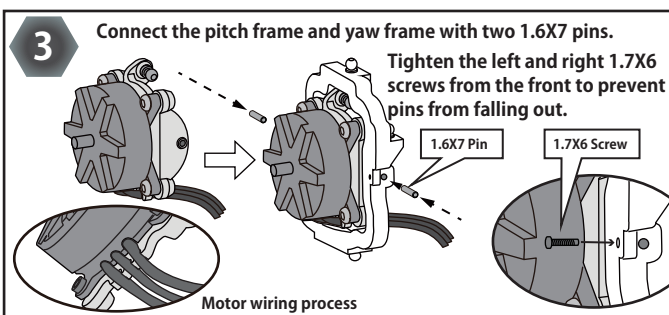
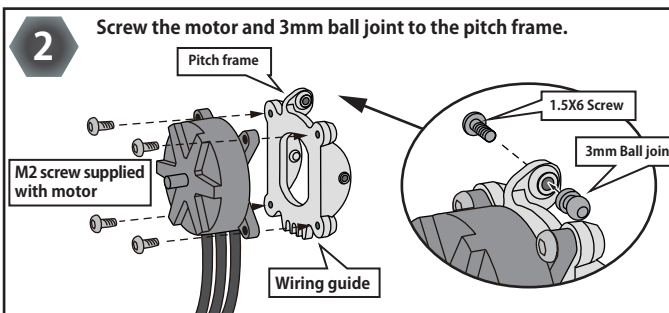
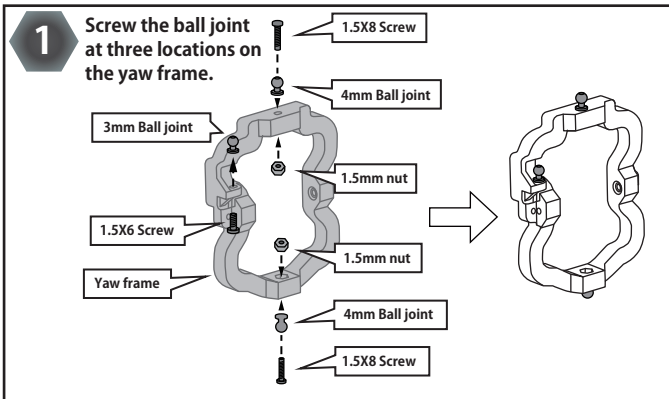
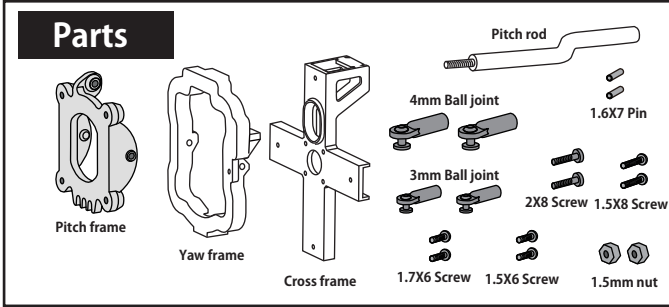

**⚠ DANGER**  
**4D Acro flight**

4D acro flight with variable thrust is a violent movement, and there is a risk of unexpected movement. 4D acro flight should be conducted in a safe place where people, buildings, cars, etc. will not be damaged after a sufficient test flight, and the operator himself must also wear a helmet and safety glasses. Fly at your own risk.

FUTABA CORPORATION

1080 Yabutsuka, Chosei-mura, Chosei-gun, Chiba-ken, 299-4395, Japan TEL: +81-475-32-6051, FAX: +81-475-32-2915

©FUTABA CORPORATION 2024, 5 (1)